

Latest results of the CODALEMA experiment: cosmic rays radio detection in a self trigger mode

Diego Torres Machado¹ for the CODALEMA collaboration^{1,2}

¹ SUBATECH, Université de Nantes/École des Mines de Nantes/IN2P3-CNRS, Nantes, France.

² LESIA, USN de Nançay, Observatoire de Paris-Meudon/INSU-CNRS, Meudon, France.

E-mail: torres@subatech.in2p3.fr

Abstract.

Dedicated to the measurement of the radio transients coming from the extensive air showers (EAS), the CODALEMA experiment was started in 2001 at the Nançay Observatory, in France. Benefiting of an easy deployment and a low cost compared with Cherenkov detectors or fluorescence telescopes, this alternative method appears to be an interesting tool for the understanding of the physics of high energy cosmic rays observed through EAS. A new configuration of the CODALEMA experiment was implemented in 2011 based on a standalone detection, which will be essential for the next generation of giant detector array. One of the major challenges of this promising detection mode is the control (identification and rejection) of the fluctuating and transient noise events in an inhabited area and the knowledge of the shower radio-detection capabilities such as the effective efficiency and the data purity. Some results concerning this new setup of the experiment will be discussed in this paper.

1. Introduction

Since its implementation in 60's [1], the cosmic rays detection through radio transients has made some significant progress from a theoretical and experimental point of view. Thanks to some technological advances, more particularly in electronics, this detection mode was relaunched in 2002 by experiments such as CODALEMA [2] in France, and LOPES [3] in Germany. The purpose of this detection method is to characterize the EAS radio signal in order to deduce the primary cosmic ray properties (energy, nature and direction). The first recorded data with CODALEMA experiment has revealed a north-south asymmetry in the arrival directions of the radio detected cosmic rays. Indeed, the charged particles of the shower are deflected by the Lorentz force and the intensity of this effect depends on the angle between the shower direction and the geomagnetic field [4]. A systematic shift between the shower core using separately data coming from scintillator and antenna arrays has been also observed [5]. This effect is associated with a charge-excess contribution in the shower radio emission.

Despite a better understanding of the mechanisms of radio emission by EAS, key elements still have to be assessed such as its ability to run on a large surface and in an inhomogeneous environment as well as its capacity to provide valuable observables sensitive to the main properties of the primary cosmic ray.

2. The experimental setup

Recently, CODALEMA has been upgraded with the installation of CODALEMA 3, composed of 34 so-called butterfly antennas (Fig. 1) and surrounding the existing short-dipole antenna array. This initial array consists of 24 dipole antennas triggered by an ensemble of 13 particle detectors. In addition to confirm the shower detection through scintillators, the energy of the primary cosmic ray can be estimated by the latter. The autonomous detection stations of CODALEMA 3 feature some new technological developments. Compared to the previous version, butterfly antenna has been designed to be more sensitive at low frequencies, which will permit the detection of EAS at large distance from its core [6]. A particular attention has been put in the reduction of its gain in the AM and FM bands in order to avoid saturating signals. Antenna signals in dual polarization (EW and NS) feed a trigger board where analog triggering decision is made on a simple voltage threshold level in a 45-55MHz filtered band. The selected events are dated by a GPS with an uncertainty of about $5ns$ and signals are digitized by an ADC (1GS/s over 2560 points for $2.56\mu s$ record). A PC and a control boards are then responsible for collecting, saving data and communication with the outer world. On the site of Nançay, communication with the autonomous stations is operated through optical fiber and powered by a dedicated electrical network. However, these stations are well able to be supplied with solar panels and to use a wireless link for communication. The block diagram of a station is presented Fig. 2, showing the main functions of the station and the links between separated boards.



Figure 1. A butterfly antenna on the field at the Nançay Observatory.

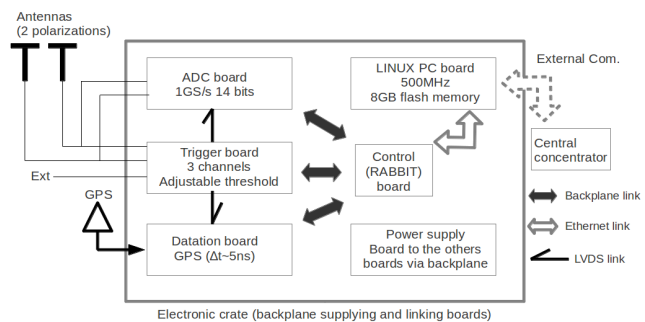

Figure 2. Schematic description of the station elements.

Using the galactic background as a calibrating signal is a very convenient way to measure the antenna sensitivity and to validate the antenna modelization with respect to calculations. Indeed, with butterfly antenna, we observe a variation of about 2.8dB of the galactic background as function of the UTC time for the 55MHz frequency, as expected by Eznec simulations [6].

3. Radio noise sources

3.1. First data set

Although the experiment is located at the Nançay Observatory in a radio-protected environment, antennas are not intrinsically shielded against radio interferences. Indeed, one of the main requirements for a radio self-triggered system is to design it for a high attenuation of man-made RFI (Radio Frequency Interferences). Data analysis were performed between march and july 2011 in order to assess the radio environment at the Nançay Observatory and consequently, the noise source features. During this period the event rate varies between 10^4 and 10^6 per day, whereas with a surface of about $0.5km^2$, one cosmic ray event within our acceptance is expected per day. Most RFI events are observed by one antenna or very few antennas and are linked to nearby (inside the array) and weak sources. Certain sources emit radio transients with a

periodicity greater than 28Hz, which implies a dead time of about 100% during their presence (Fig 3). Therefore, it becomes essential for an optimal operation of the experiment to identify and control the radio noise sources. Furthermore, the localization and knowledge of the nature of the source can give information on the radio detection sensitivity as well as on the direction reconstruction accuracy.

3.2. Reconstruction of the radio signal front

Concerning nearby noise sources, in first approximation, the radio wave front can be assumed to be spherical and emitted by point-like sources on the ground. Reconstruction method makes use only of the measured arrival times of the radio signal at the individual antennas, and its accuracy will depend strongly on the time resolution of the detector. The position of the source will be associated to the coordinates for which the deviation evaluated with a χ^2 , between the radio wave and the sphere is minimum (Fig. 4). Due to uncertainties regarding the reconstruction, a large number of events is required in order to have a pertinent mean value. Thus, some man-made noise sources have been located in the vicinity of the Nançay Observatory and electric transformer stations are the most likely candidates.

Other online methods are being tested currently on the field as the elimination of periodic events and selection by wave form analysis. A fast reconstruction of the arrival direction before its recording is also conceivable in T3 level trigger in order to eliminate events coming from the horizon.

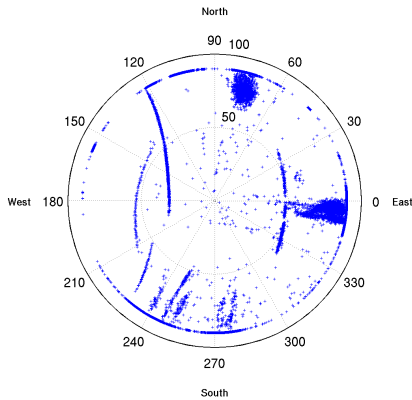

Figure 3. Arrival direction of the reconstructed events for one day of data taking. We can observe the trajectory of some planes and a large number of events near the horizon, that correspond to noise sources.

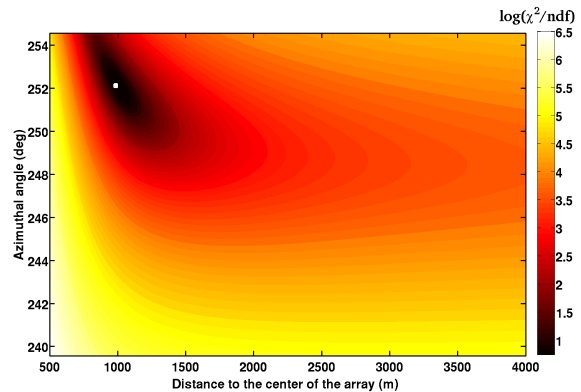

Figure 4. χ^2 evolution as function of the source position on the ground. This source is located at 252°(SW) and at 1050m from the center of the array (white dot).

4. EAS detection

EAS has been detected by standalone stations since its start-up in 2011 and recent studies suggests that their identification can be confirmed by one single station [7]. Assuming that the geomagnetic effect is the only mechanism of signal production, the electric field vector is predicted to be along $\mathbf{v} \times \mathbf{B}$, and its projection on the ground ψ_{pred} is supposed to be equal to the projection of the measured field with respect to the north direction $\psi_{meas} = \arctan(E_{EW}/E_{NS})$, where E_{EW} and E_{NS} are the max of the transient electric field measured in each polarization. Arrival directions \mathbf{v} are provided by the dipole antenna array and \mathbf{B} is the geomagnetic field

at Nançay. Figure 5 shows transients in EW and NS polarizations for an event coming from the North. As the geomagnetic field lines at Nançay are directed toward the south, $\mathbf{v} \times \mathbf{B}$ is supposed to be mostly along EW polarization. Figure 6 shows the evolution of $\psi_{pred} = f(\psi_{meas})$ for a small collection of events.

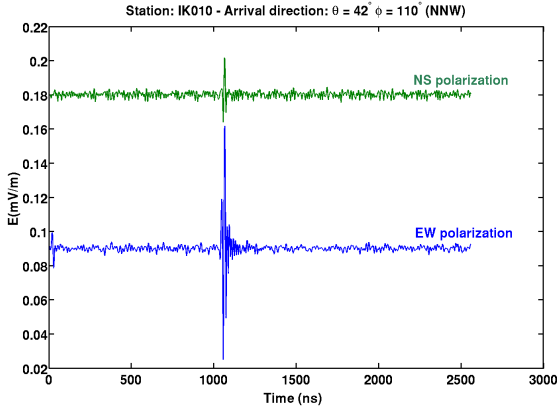

Figure 5. Wave shape for both EW and NS polarizations of the electric field filtered in the 30-80MHz band.

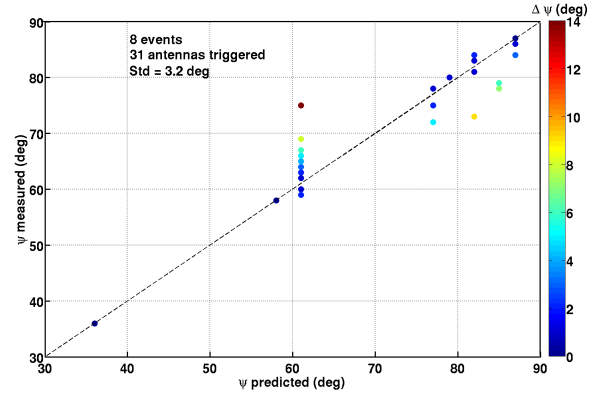

Figure 6. Polarization angle ψ_{pred} calculated according to $\vec{v} \times \vec{B}$ as function of ψ_{meas} deduced from the antenna signals. The angular difference $\psi_{meas} - \psi_{pred}$ are represented by colors.

Despite a relative good agreement shown in Fig. 6, some effects should be taken into account such as the charge excess contribution, azimuthal angle and frequency range. Studies should be also carried out on the antenna response relative to the arrival direction of the signal. Besides confirming the geomagnetic effect as the main mechanism, this identification criterion can also be interesting to remove background sources.

5. Conclusion

The CODALEMA experiment has made great progresses over the recent years in the understanding on the electric field emission coming by EAS. First results of CODALEMA 3 have shown an antenna sensitivity to the galactic background but also to man-made radio emitting inside and in the vicinity of the Nançay Observatory. Reconstruction methods has been applied successfully and main radio background sources has been identified. Rejection methods based on emission periodicity and pulse shape analysis have been tested on data and have demonstrated to be efficient, while preserving EAS candidates.

From a physics point of view, a polarization signature of the geomagnetic emission mechanism is clearly present in this data set. Although the statistics on this data set are low, the polarization studies show promising results.

References

- [1] Jelley J V *et al* 1965 *Nature* **205** 327.
- [2] Ardouin D *et al* 2005 *Nucl. Instrum. Meth. A* **555** 148-163.
- [3] Falcke H *et al* 2005 *Nature* **435** 313.
- [4] Ardouin D *et al* 2009 *Astropart. Phys* **31** 192-200.
- [5] Marin V for the CODALEMA collaboration 2011 *Proc. Int. Conf. on Cosmic Ray (Beijing)*.
- [6] Charrier D 2012 *Nucl. Instrum. Meth. A* **662** 142-1145.
- [7] Belletoile A for the CODALEMA collaboration 2011 *Proc. Int. Conf. on Cosmic Ray (Beijing)*.